

ELIMINATOR

EMF HAMMERMILL

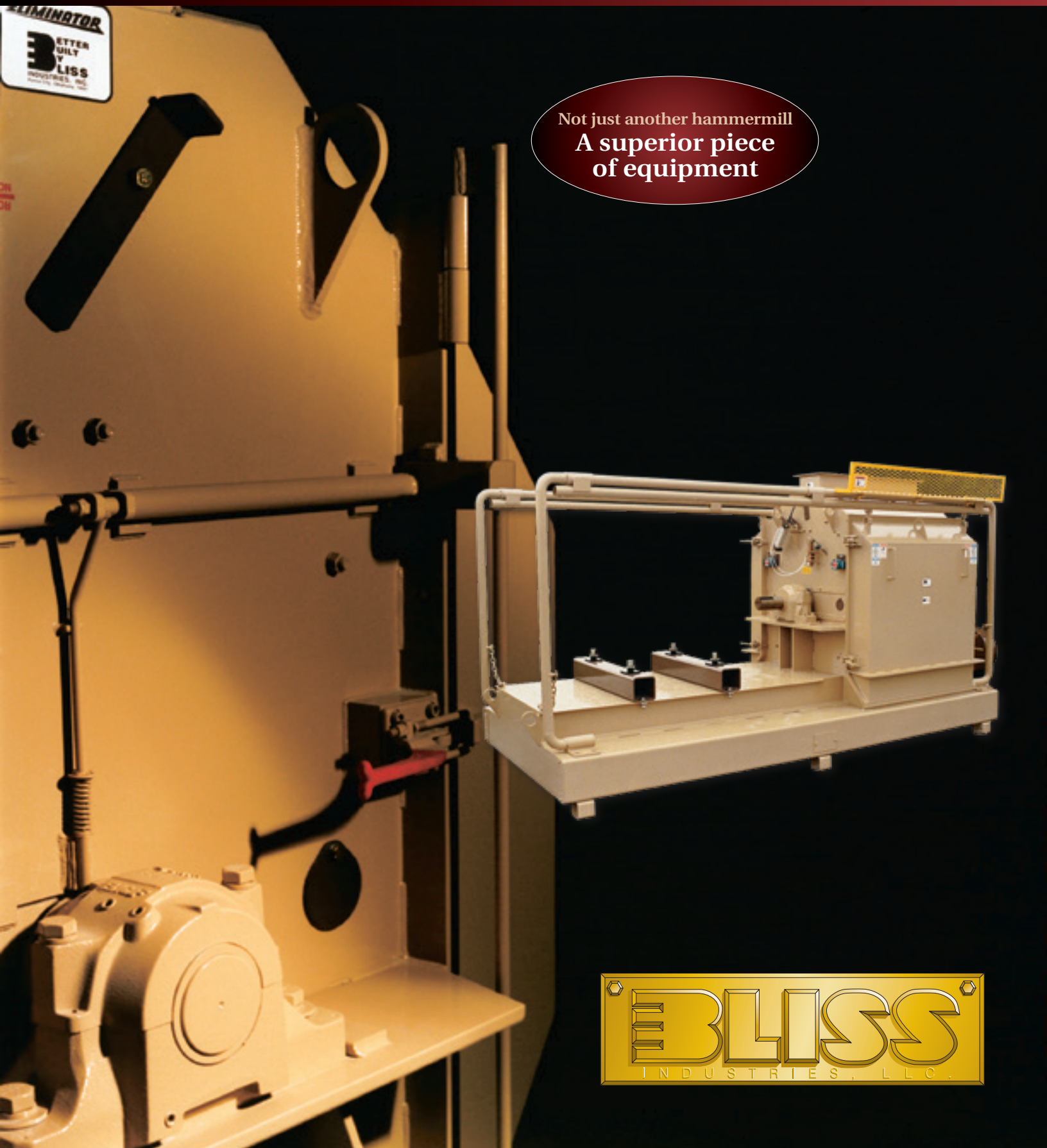

Not just another hammermill
**A superior piece
of equipment**

BLISS
INDUSTRIES, LLC.

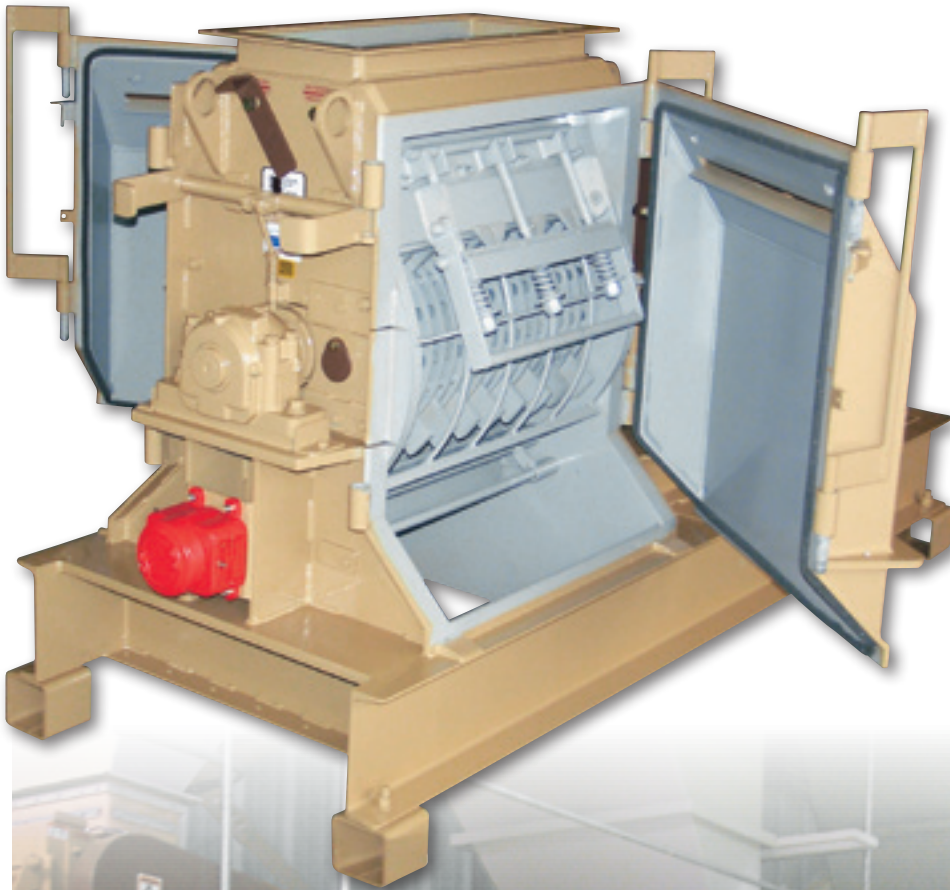

The Eliminator Fine Grind Hammermill is designed to fill the gap in granulations between a traditional hammermill and an air swept pulverizer or fine grinder. The granulation range of the EMF mill is in the 40 – 100 mesh range depending on the product and application.

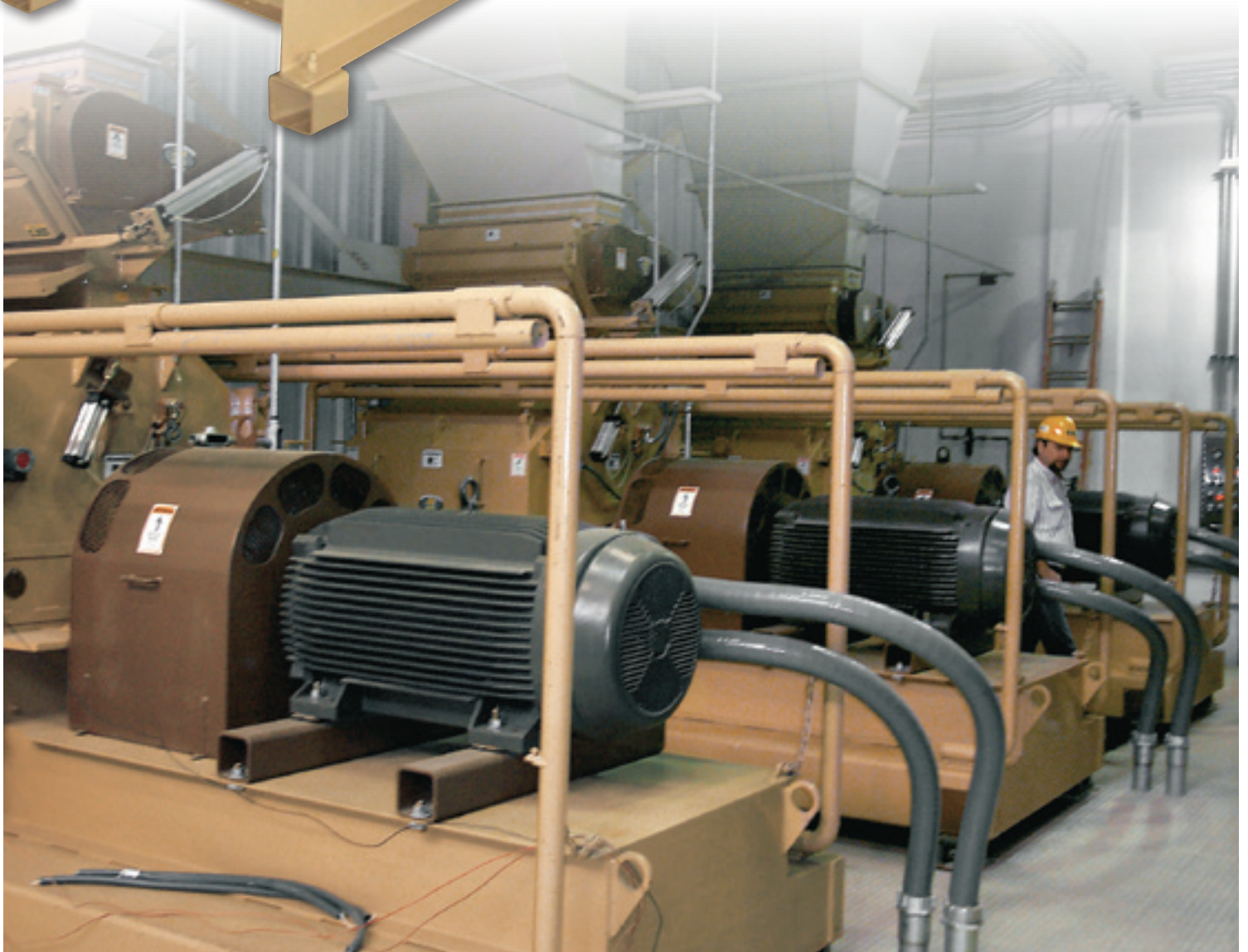

EMF HAMMERMILL

PRODUCT	SCREEN SIZE	LBS/HP-HR	KW/TONNE	AVERAGE MICRON	STD. DEV.	+60 U.S. MESH 250 MICRON	-60 U.S. MESH 250 MICRON
FISH FOOD	.027	75	21.8	72	1.783	5%	95%
SHRIMP FOOD	.027	60	27.2	89	1.869	5%	95%
CAT FOOD	3/64	100	16.3	240	1.456		
DOG FOOD	.055	105	21.0	197	1.854		

BLISS MEDIUM FINE GRINDER DIMENSIONS

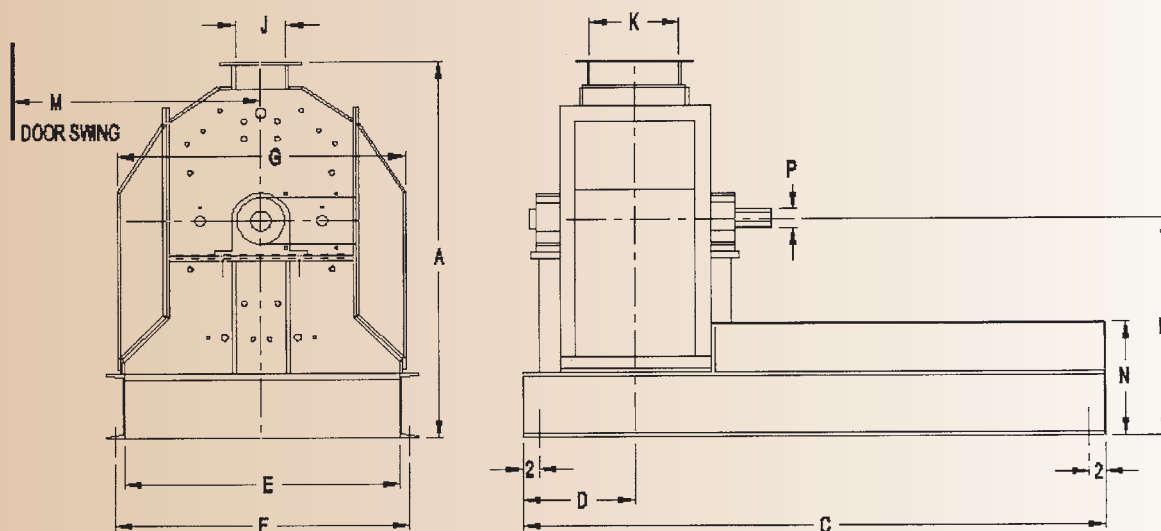

MILL DIMENSIONS (INCHES)

MODEL	KW	RPM	A	B	C	D	E	F	G	J	K	M	N	P	OUTLET	SCREEN AREA (IN ²)	WEIGHT (LBS)
EMF-24115	40-60	3600	46.8	27	70	14.2	33	35.3	34.6	6	10.8	30	**	2.4	15.9 x 58	258.8	1538
EMF-2415	60-75	3600	46.8	27	72	15.3	33	35.3	34.6	6	14.3	34	**	2.4	20.9 x 58	337.5	1800
EMF-24120	75-100	3600	46.8	27	76	17.8	33	35.3	34.6	6	19.3	38	**	2.4	24.9 x 58	450	2125
EMF-24130	125-150	3600	46.8	27	82	23.4	33	35.3	34.6	6	29.3	48	**	2.9	32.3 x 58	675	2600
EMF-24140	150-200	3600	46.8	27	124	28.4	33	35.3	34.6	6	39.3	58	**	4.4	42.3 x 58	900	3100

MILL DIMENSIONS (MILLIMETERS)

MODEL	HP	RPM	A	B	C	D	E	F	G	J	K	M	N	P	OUTLET	SCREEN AREA (CM ²)	WEIGHT (KG)
EMF-24115	30-45	3600	1187.5	685.8	1778	360.4	838.2	895.4	1803.4	152.4	273.1	762	**	61.9	403 x 1473	1669.35	698
EMF-2415	45-56	3600	1187.5	685.8	1828.8	388.6	838.2	895.4	1803.4	152.4	362	864	**	61.9	530 x 1473	2177.42	817
EMF-24120	56-75	3600	1187.5	685.8	1930.4	452.1	838.2	895.4	1803.4	152.4	489	965	**	61.9	632 x 1473	2903.22	965
EMF-24130	93-112	3600	1187.5	685.8	2082.8	595.3	838.2	895.4	1803.4	152.4	743	1219	**	73.7	819 x 1473	4354.83	1180
EMF-24140	112-149	3600	1187.5	685.8	3149.6	722.3	838.2	895.4	1803.4	152.4	997	1473	**	112.7	1073 x 1473	5806.44	1407

3000 RPM for a 50 cycle operation

NOTE: All dimensions and specifications are subject to change without obligation or notice.

This drawing is not meant to be used for fabrication purposes, contact Bliss Engineering Dept for certified drawings.

** Variable Dimension



- The Eliminator Medium Fine Grind Hammermill utilizes cutter and/or impact plates.
- The hammer to screen clearance (cutter plate and/or impact plate) is much closer than traditional hammermill designs.
- Produces granulations in the 40 – 100 mesh range dependent upon product and application.
- Utilizes higher peripheral tip speed than standard hammermills.
- All grinding is done against replaceable wear parts.
- Easily replaceable wear parts.
- Extra fine grind screen carriage for positive seal to prevent leakage.

ELIMINATOR EMF HAMMERMILL SPECIFICATIONS

Model	24115	2415	2420	*2430	**2440	4815	4820	4824	*4830	**4840	**4848
Horsepower	40-50	60-75	75-100	100-150	150-200	100-150	150-200	150-250	200-300	250-400	300-500
Diameter	24"	24"	24"	24"	24"	48"	48"	48"	48"	48"	48"
Width	11.5"	15"	20"	30"	40"	15"	20"	24"	30"	40"	48"
RPM	3600	3600	3600	3600	3600	1800	1800	1800	1800	1800	1800

* Indicates dual grind chamber as standard.

** Indicates dual grind chamber & sliding doors as standard equipment.



WARNING LABELS
"Industry Standard" Safety Warning Labels are applied as recommended and prepared by the AFIA Equipment Manufacturers Council.

Represented by:



Impacting Industries Worldwide.

Bliss Industries, Inc.
P.O. Box 910 • Ponca City, Oklahoma U.S.A. 74602
Phone (580) 765-7787 • Fax (580) 762-0111
Internet: <http://www.bliss-industries.com>
E-mail: sales@bliss-industries.com